

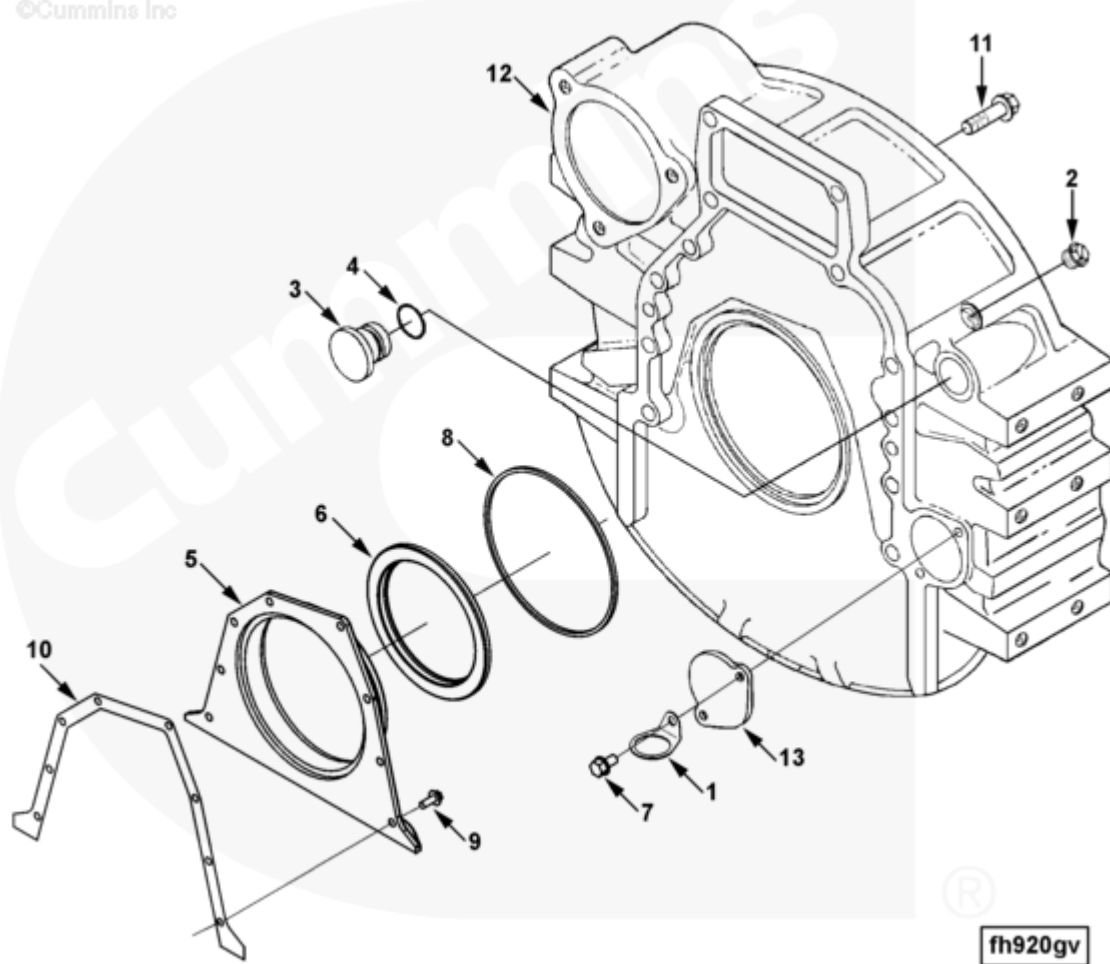

Parts Catalog - Option Detail

Electronic Parts Catalog - Option Detail				
Option	Group	Graphic	Film Card	Date
FH9032-02	16.01	fh920gv	Z	15-OCT-98
Engines	6C8.3, C GAS PLUS CM556, G8.3, G8.3 CM558, GTA8.3 CM558, ISC CM2150, ISC CM554, ISC CM850, ISC8.3 CM2250, ISC8.3 G CM2180 C101, ISL CM2150, ISL CM554, ISL CM850, ISL G CM2180, ISL8.9 CM2150 L110, ISL8.9 CM2880 L112, ISL9 CM2150 SN, ISL9 CM2250, ISL9 CM2350 L101, ISL9 CM2350 L111, ISLE4 CM850, L GAS PLUS CM556, L8.9, L8.9 L121, L8.9G CMOH2.0 L125B, L9 CM2350 L116B, L9 CM2350 L119B, L9 CM2350 L120C, L9 CM2350 L123B, L9.3 L105, L9.5 L117, L9N CM2380 L124B, QSC8.3 CM2250, QSC8.3 CM2880 C102, QSC8.3 CM554, QSC8.3 CM850(CM2850), QSL9 CM2250, QSL9 CM2250 L115, QSL9 CM2350 L102, QSL9 CM2350 L107, QSL9 CM2350 L118, QSL9 CM2350 L122, QSL9 CM554, QSL9 CM850(CM2850), QSL9 G CM558, QSL9 M CM2250 L106, QSL9.3 CM2880 L113			



SMALL | MEDIUM | LARGE

Cart	Ref No	Part Number	Part Description	Required	Remarks
View My Cart					
		FH9032-02	Flywheel Housing		

				Engine Design Phase: Current
				Product
				Wet/Dry Clutch: Dry
				Housing Material: Aluminum
				SAE Size or Type: SAE 2
				Starter Mount SAE: SAE #3 -
				3 Bolt 120 degree
				Starter Mount Thread Type:
				Metric
				St Quadrant: 1st
				Starter Pad Offset from RFOB
				(mm): 0.00
				Starter Mounting Hole
				Diameter (mm): 106.0
				Mount Type: Pad
				Engine Mounting Hole
				Dimension: M12x1.75-6H
				# Mount Holes: 12
				Engine Mount Top Hole +/- CR
				C/L (mm): 104.78
				Tach Sensor Location: 4th
				Tach Size: 3/4 - 16 UNF
				Tach Count: 1
				Trans Mt Holes Count/Thread:
				12 - M10 x 1.50 6H
				Starter Pad +/- CR C/L Y Axis
				(mm): 157.59
				Starter Pad +/- CR C/L X Axis
				(mm): 181.29
				Starter Bore Angle (deg): 49

					Flywheel Housing Attachment
					Provision: Cylinder Block
					Starter Center Distance:
					240.21
					Doweled for Oil Pan: No
					Engine Family: C Series
					Brazil may use Rear Cover p/n
					3357700 instead of p/n
					3911699.
<input type="checkbox"/>	1	3928989	Clip	1	
<input type="checkbox"/>	2	3904181	Threaded Plug	1	3/4 - 16 UNF
<input type="checkbox"/>	3	3910248	O-Ring Plug	1	
<input type="checkbox"/>	4	3910260	O-Ring Seal	1	
		3911699	Rear Cover	1	Order Individual Parts.
<input type="checkbox"/>	5	3933384	Rear Cover	1	
<input type="checkbox"/>	6	3933262	Oil Seal	1	Serviced as 3934486.
					tools
<input type="checkbox"/>	7	3912072	Self Tapping Metal Screw	2	M8 x 1.25 x 15
<input type="checkbox"/>	8	3912473	Rectangular Ring Seal	1	
<input type="checkbox"/>	9	3913638	Hexagon Flange Head Cap Screw	8	M6 X 1.00 X 16.
<input type="checkbox"/>	10	3914301	Rear Cover Gasket	1	
<input type="checkbox"/>	11	3920447	Hexagon Flange Head Cap Screw	12	M12 X 1.75 X 40.
<input type="checkbox"/>	12	3906689	Flywheel Housing	1	
<input type="checkbox"/>	13	3925234	Cover Plate	1	